

Goldberg Brothers

Soft Stop - Standard and MP Series

To install, loosen lag bolts on front side of track and position the Soft Stop system on the back side with the device being closest to the wall.

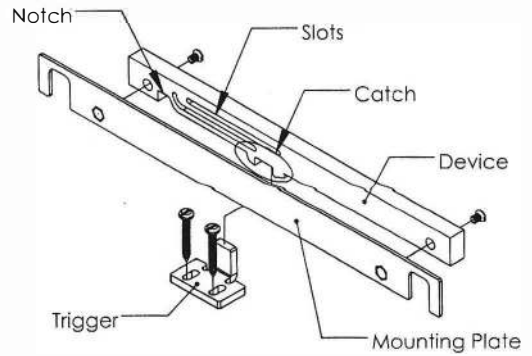
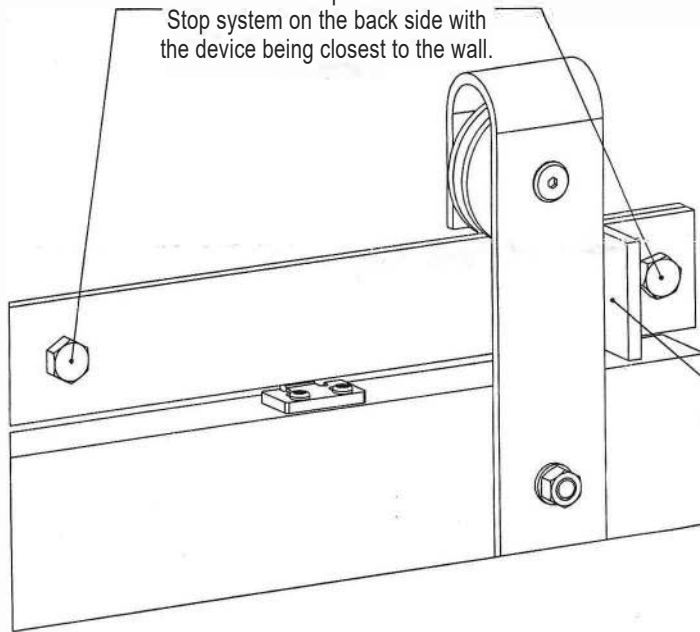

NOTE: Instructions apply to all standard 11 inch and 17 inch Soft Stop systems. Mounting plates with custom hole patterns greater than 11 inches can be manufactured upon request.

Before installing trigger, clamp hanger against stop to ensure proper alignment when door is in the open or closed position.

Catch should be positioned as shown for proper trigger installation.

For proper operation, device should be installed with the notch OR curved slot** sitting closest to the center of the track.

Mounting plate should sit flush* against the back side of the track, between the track and spacers.

If necessary, the mounting plate can be adjusted to sit higher, to ensure that the trigger fits properly without hitting or scraping the device.

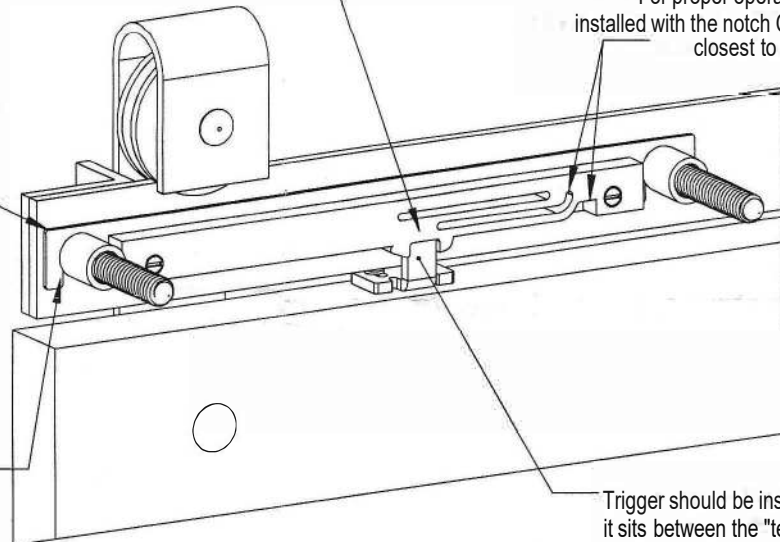

Trigger should be installed so that it sits between the "teeth" of the catch on the device.

Goldberg Born Door Track and Hardware sets come with a one year manufacturer's warranty for defective parts under normal installation and use. Warranty is subject to repair or replacement of defective part(s) at manufacturer's discretion and does not include installation costs. Goldberg Brothers does not warrant the loss of finish at points where roller is in contact with track. Goldberg Born Track is sold as a rustic finished hardware and Goldberg does not warrant the imperfections seen through the finish in the steel parts, as it is part of the look.

* Mounting Plate will sit a quarter inch off the back side of the track for Stainless systems.

** Device will have either two slots OR one notch, based on the system and the weight of the door.

This document contains proprietary information of Goldberg Brothers, Inc., and its receipt of possession does not convey any rights to reproduce or disclose its contents, or to manufacture, use, or sell anything it may describe. Reproduction, disclosure, or use without prior written authorization of Goldberg Brothers, Inc. is strictly forbidden.

GOLDBERG BROTHERS, INC.
 Denver, CO
 303-321-1099

GOLDBERG BROTHERS

SOFT STOP INSTALLATION TROUBLESHOOTING GUIDE

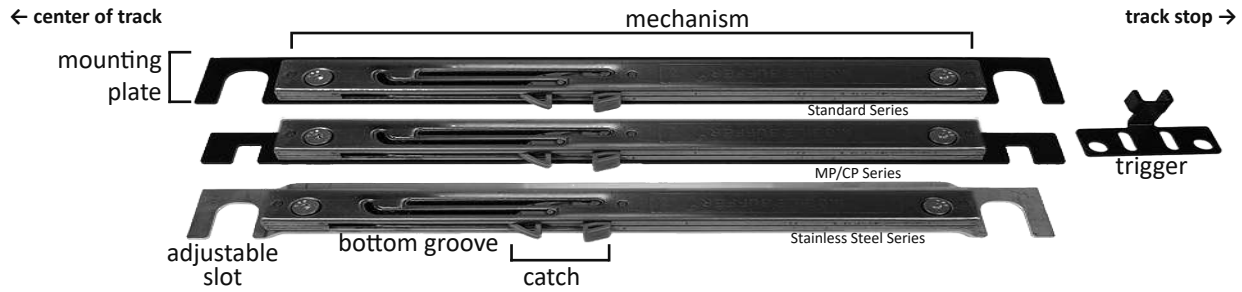

Do you have the correct Soft Stop kit to match your track?

The most common installation problems are due to a mismatch between the track hardware and the Soft Stop kit. As you can see in the illustration above, the mounting plates are different for Standard Series, MP/CP Series, and Stainless Steel Series. They are not freely interchangeable. The hardware series is indicated by the first four digits in the SKU or catalog number and should be the same for both the Soft Stop kit and the barn door hardware set. **Standard Series: 6001 • MP/CP Series: 6008 • Stainless Steel Series: 6005.** There is no Soft Stop kit currently available for Shutter Series, Hidden Roller Series, or Barnfold® Series barn door hardware.

Is the mounting plate the correct length?

We make mounting plates to fit over track lag bolts that are either 11 or 17 inches apart (center-to-center). Goldberg Brothers tracks that are 4 to 7 feet long need an 11-inch Soft Stop Kit. Goldberg Brothers tracks that are 8 feet or longer require a 17-inch Soft Stop kit. The mounting plate length is indicated by an 11 or 17 in the SKU or catalog number. **Standard Series: 6001SOFT11, 6001SOFT17 • MP/CP Series: 6008SOFT11, 6008SOFT17 • Stainless Steel Series: 6005SOFT 11, 6005SOFT17.**

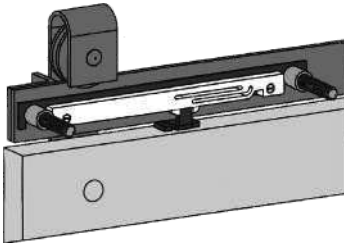

In most installations, the mounting plates go against the back of the track, over the first and second lag bolts from each end of the track. Or with custom-length mounting plates, they can go over the second and third lag bolts from each end of the track. The sides of the adjustable slots are pinched between the track and the spacers that cover the lag bolts. It is not necessary for the hook to rest directly on the bolt. By slightly loosening the lag bolts, the mounting plate can be moved up or down as necessary to properly align the catch with the trigger.

Do not remove the track stops. The Soft Stop system works with the track stops. It does not replace them. **Using a Soft Stop system without a track stop will void the limited 1-year warranty.**

The Soft Stop mechanism is not unbreakable. **Deliberately rolling the door against the Soft Stop system with excessive force may damage the catch or the hydraulic cylinder and will void the limited 1-year warranty.**

PROBLEM	SOLUTION
The two track lag bolts where the Soft Stop system will be installed are neither 11 nor 17 inches apart, so the mounting plate will not fit over them.	<ul style="list-style-type: none"> You are trying to use Goldberg Brothers Soft Stop with another manufacturer's track or with custom drilled holes or an otherwise modified track. The mounting plates are specifically sized to fit the standard spacing and diameter of the two outermost factory-punched holes in Goldberg Brothers tracks. Contact your dealer to order custom-sized mounting plates to fit track holes spaced more than 11 inches apart. A solution may not be available for some tracks not made by Goldberg Brothers.
The trigger moves under the catch and does not engage it.	<ul style="list-style-type: none"> The Soft Stop system is too high. Slightly loosen the two lag bolts that hold the Soft Stop mounting plate. Move the mounting plate down to the correct height, then re-tighten the lag bolts. If this adjustment does not solve the problem, the gap between the bottom of the track and the top of the door is too great. Place a wood shim under the trigger to raise it enough to engage the catch.
The trigger hits the end of the mechanism and the door will not move any further.	<ul style="list-style-type: none"> The Soft Stop system is too low. Slightly loosen the two lag bolts holding the Soft Stop mounting plate. Move the mounting plate up to the correct height, then re-tighten the lag bolts.
The two mechanisms in the Soft Stop kit look identical. They are not oriented in opposite directions for installing on the left and right sides.	<ul style="list-style-type: none"> We made a mistake putting your order together, but the fix is easy. On one of the two mechanisms, remove the two screws that hold it against the mounting plate, flip it over, then reattach the screws.
The trigger hits the catch but the door will not move any further.	<ul style="list-style-type: none"> The left and right Soft Stop systems may be on the wrong ends of the track. If so, loosen the lag bolts and swap the two systems. When installed correctly, the bottom grooves will be oriented toward the center of the track, away from the track stops.
With a lightweight door and Standard Series or Stainless Steel Series hardware, the Soft Stop mechanisms make the door too difficult to open or close.	<ul style="list-style-type: none"> Contact your dealer to substitute the Standard Series mechanisms with lower-load mechanisms that work better with lightweight doors. Substitute mechanisms are available by special order. You can keep and use the same mounting plates and triggers.
Over time and with repeated use, the trigger has rotated or moved out of the correct position.	<ul style="list-style-type: none"> If your trigger does not look like the one in the illustration above, you have our old trigger that is secured with two screws. Contact your dealer to order a replacement trigger that is secured with four screws.
The trigger and catch engage correctly, but the moving door does not slow down.	<ul style="list-style-type: none"> The hydraulic cylinder inside the mechanism may be worn or damaged. This can be due to normal wear-and-tear or repeatedly sliding the door with excessive force. You can test the mechanism by rolling the door out of the way, then manually pushing the largest side of the catch along the bottom groove until it stays in the "loaded" position. A gentle push in the opposite direction, against the small side of the catch, should make the catch return slowly to its original position. If it does not move at all or if it snaps back quickly, the hydraulic cylinder is no longer working properly. Contact your retail dealer to purchase a replacement mechanism. You can still use the same mounting plate and trigger.